

**EROSION AND SEDIMENT CONTROL NARRATIVE:**

**PRINCIPLES OF EROSION AND SEDIMENT CONTROL**

The primary function of erosion and sediment controls is to absorb erosional energies and reduce runoff velocities that force the detachment and transport of soil and/or encourage the deposition of eroded soil particles before they reach any sensitive area.

**KEEP LAND DISTURBANCE TO A MINIMUM**

The more land that is in vegetative cover, the more surface water will infiltrate into the soil, thus minimizing stormwater runoff and potential erosion. Keeping land disturbance to a minimum not only involves minimizing the extent of exposure at any one time, but also the duration of exposure. Phasing, sequencing and construction scheduling are interrelated. Phasing divides a large project into distinct sections where construction work over a specific area occurs over distinct periods of time and each phase is not dependent upon a subsequent phase in order to be functional. A sequence is the order in which construction activities are to occur during any particular phase. A sequence should be developed on the premise of "first things first" and "last things last" with proper attention given to the inclusion of adequate erosion and sediment control measures. A construction schedule is a sequence with time lines applied to it and should address the potential overlap of actions in a sequence which may be in conflict with each other.

- Limit areas of clearing and grading. Protect natural vegetation from construction equipment with fencing, tree armoring, and retaining walls or tree wells.
- Route traffic patterns within the site to avoid existing or newly planted vegetation.
- Phase construction so that areas which are actively being developed at any one time are minimized and only that area under construction is exposed. Clear only those areas essential for construction.
- Sequence the construction of storm drainage systems so that they are operational as soon as possible during construction. Ensure all outlets are stable before outletting storm drainage flow into them.
- Schedule construction so that final grading and stabilization is completed as soon as possible.

**SLOW THE FLOW**

Detachment and transport of eroded soil must be kept to a minimum by absorbing and reducing the erosive energy of water. The erosive energy of water increases as the volume and velocity of runoff increases. The volume and velocity of runoff increases during development as a result of reduced infiltration rates caused by the removal of existing vegetation, removal of topsoil, compaction of soil and the construction of impervious surfaces.

- Use diversions, stone dikes, silt fences and similar measures to break flow lines and dissipate storm water energy.
- Avoid diverting one drainage system into another without calculating the potential for downstream flooding or erosion.

**KEEP CLEAN RUNOFF SEPARATED**

Clean runoff should be kept separated from sediment laden water and should not be directed over disturbed areas without additional controls. Additionally, prevent the mixing of clean off-site generated runoff with sediment laden runoff generated on-site until after adequate filtration of on-site waters has occurred.

- Segregate construction waters from clean water.
- Divert site runoff to keep it isolated from wetlands, watercourses and areas that flow through or near the development until the sediment in that runoff is trapped or detained.

**REDUCE ON SITE POTENTIAL INTERNALLY AND INSTALL PERIMETER CONTROLS**

While it may seem less complicated to collect all waters to one point of discharge for treatment and just install a perimeter control, it can be more effective to apply internal controls to many small sub-drainage basins within the site. By reducing sediment loading from within the site, the chance of perimeter control failure and the potential off-site damage that it can cause is reduced. It is generally more expensive to correct off-site damage than it is to install proper internal controls.

- Control erosion and sedimentation in the smallest drainage area possible. It is easier to control erosion than to contend with sediment after it has been carried downstream and deposited in unwanted areas.
- Direct runoff from small disturbed areas to adjoining undisturbed vegetated areas to reduce the potential for concentrated flows and increase settlement and filtering of sediments.
- Concentrated runoff from development should be safely conveyed to stable outlets using rip rapped channels, waterways, diversions, storm drains or similar measures.
- Determine the need for sediment basins. Sediment basins are required on larger developments where major grading is planned and where it is impossible or impractical to control erosion at the source. Sediment basins are needed on large and small sites when sensitive areas such as wetlands, watercourses, and streets would be impacted by off-site sediment deposition. Do not locate sediment basins in wetlands or permanent or intermittent watercourses. Sediment basins should be located to intercept runoff prior to its entry into the wetland or watercourse.

**SEPTIC SYSTEM CONSTRUCTION NOTES**

1. The building, septic system and well shall be accurately staked in the field by a licensed Land Surveyor in the State of Connecticut, prior to construction.
2. Topsoil shall be removed and in the area of the primary leaching field scarified, prior to placement of septic fill. Septic fill specifications are as follows:
  - Max. percent of gravel (material between No. 4 & 3 inch sieves) = 45%

GRADATION OF FILL (MINUS GRAVEL)		
SIEVE SIZE	PERCENT PASSING (WET SIEVE)	PERCENT PASSING (DRY SIEVE)
No. 4	100%	100%
No. 10	70% - 100%	70% - 100%
No. 40	10% - 50%	10% - 75%
No. 100	0% - 20%	0% - 5%
No. 200	0% - 5%	0% - 2.5%

Fill material shall be approved by the sanitarian prior to placement. It shall be compacted in 6" lifts and shall extend a minimum of five feet (5') around the perimeter of the system. Common fill shall extend an additional five feet (5') down gradient of the system (10' total) before tapering off at a maximum slope of 2H:1V.

3. Septic tank shall be two compartment precast 1000 gallon tank with gas deflector and outlet filter as manufactured by Jolley Precast, Inc. or equal.
4. Distribution boxes shall be 4 hole precast concrete as manufactured by Jolley Precast, Inc. or equal.
5. All precast structures such as septic tanks, distribution boxes, etc. shall be set level on six inches (6") of compacted gravel base at the elevations specified on the plans.
6. Solid distribution pipe shall be 4" diameter PVC meeting ASTM D-3034 SDR 35 with compression gasket joints. It shall be laid true to the lines and grades shown on the plans and in no case shall have a slope less than 0.125 inches per foot.
7. Perforated distribution pipe shall be 4" diameter PVC meeting ASTM D-3034 or ASTM F1760 for SDR 35, or ASTM F810 for SDR 36.
8. Sewer pipe from the foundation wall to the septic tank shall be schedule 40 PVC meeting ASTM D 1785. It shall be laid true to the grades shown on the plans and in no case shall have a slope less than 0.25 inches per foot.
9. Solid footing drain outlet pipe shall be 4" Diameter PVC meeting ASTM D 3034, SDR 35 with compression gasketed joints. Footing drain outlet pipe shall not be backfilled with free draining material, such as gravel, broken stone, rock fragments, etc.
10. Septic sand shall meet the requirements of ASTM C-33 with less than 10% passing a 100 sieve and less than 3% passing a 200 sieve

SIEVE SIZE	% PASSING
0.375	100
#4	95-100
#8	80-100
#16	60-85
#30	25-60
#50	10-30
#100	<10
#200	<5

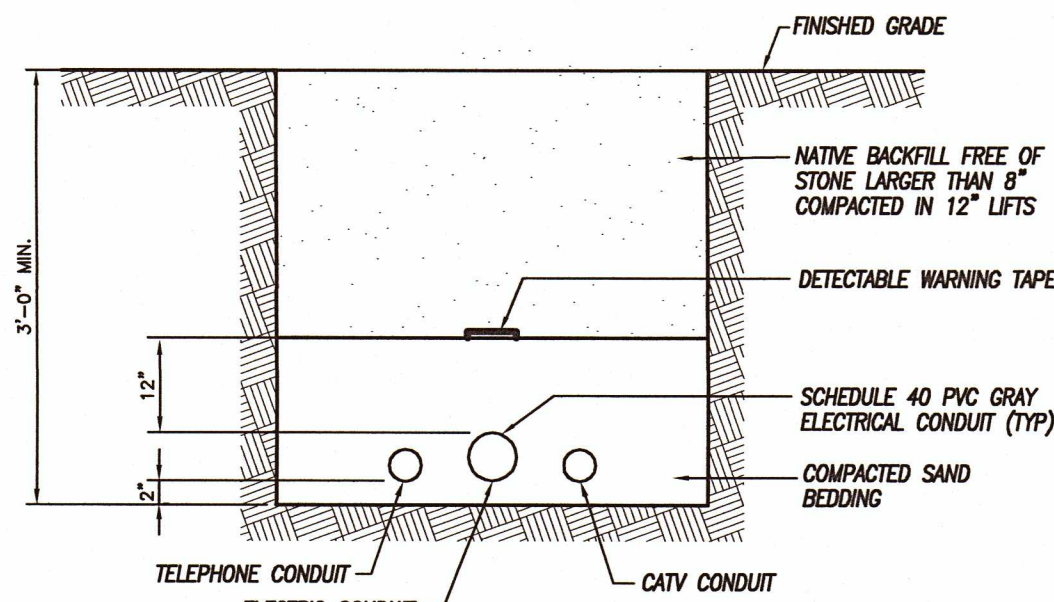

NOTE: CONTRACTOR SHALL PROVIDE SILT/CLAY DAMS AT 100' INTERVALS ALONG PROPOSED UTILITY TRENCH TO AVOID TRANSPORTING INTERCEPTED WATER.

**UNDERGROUND UTILITY TRENCH**

NOT TO SCALE

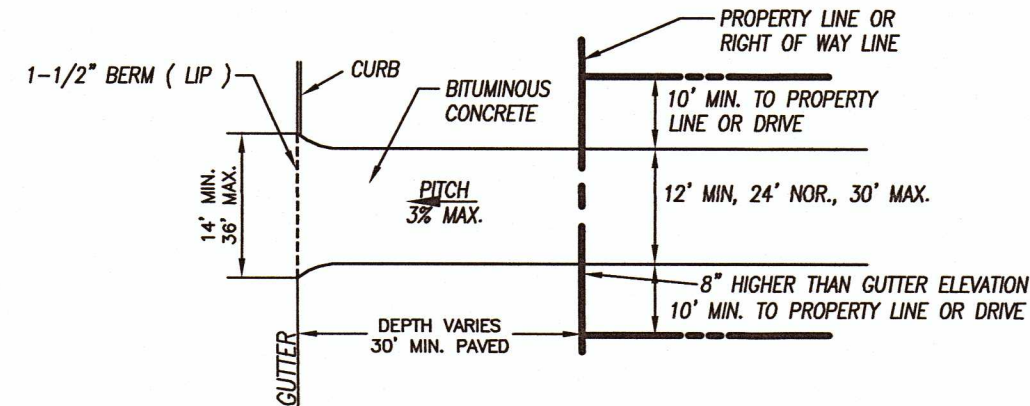

**PLAN VIEW**

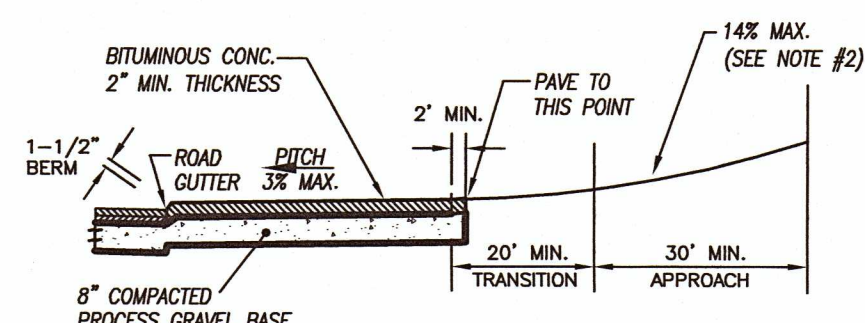

**LAND ABOVE ROAD (SECTION)**

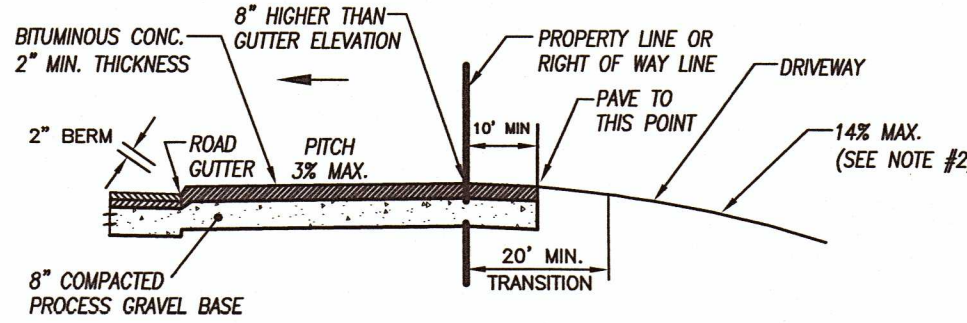

**LAND BELOW ROAD (SECTION)**

1. THE ABOVE DETAIL IS ILLUSTRATIVE ONLY AND DOES NOT APPLY TO EVERY SITUATION. REVIEW YOUR DRIVEWAY PERMIT FOR YOUR SPECIFIC REQUIREMENTS.
2. DRIVEWAYS IN EXCESS OF 10% GRADE, AND ALL COMMON (SHARED) DRIVEWAYS SHALL BE PAVED WITH BITUMINOUS CONCRETE.

**STANDARD DRIVE DETAIL**

NOT TO SCALE

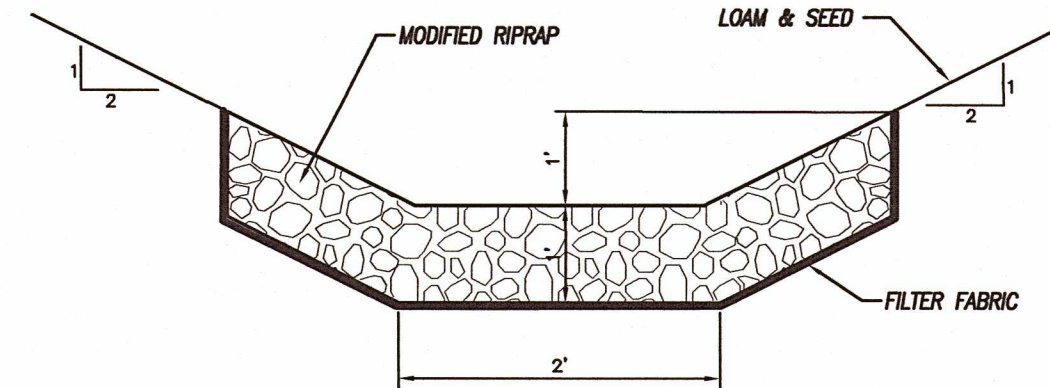

**MODIFIED RIPRAP SWALE**

NOT TO SCALE

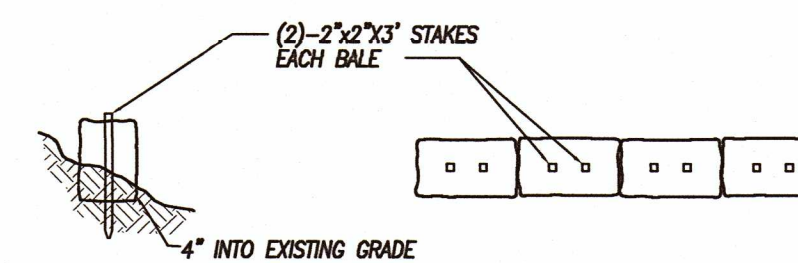

**HAYBALE BARRIER**

NOT TO SCALE

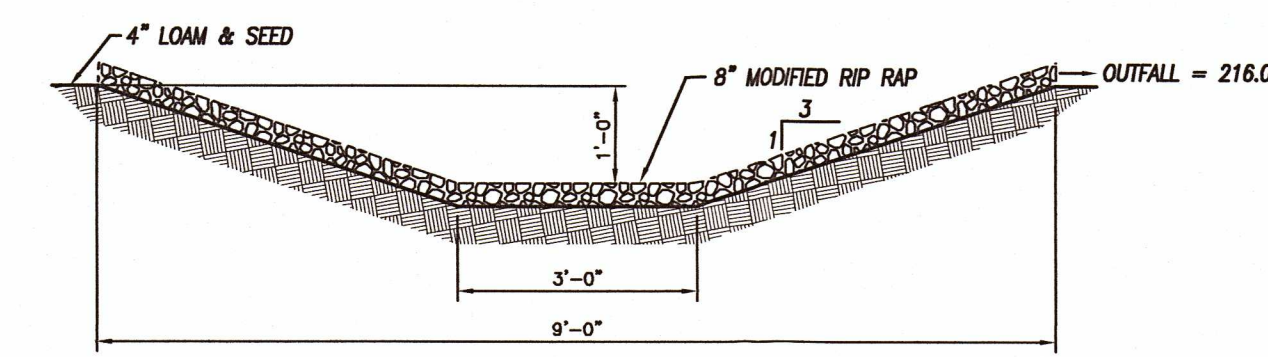

**SECTION THROUGH LEVEL SPREADER**

NOT TO SCALE

**ANTI-TRACKING PAD**

NOT TO SCALE

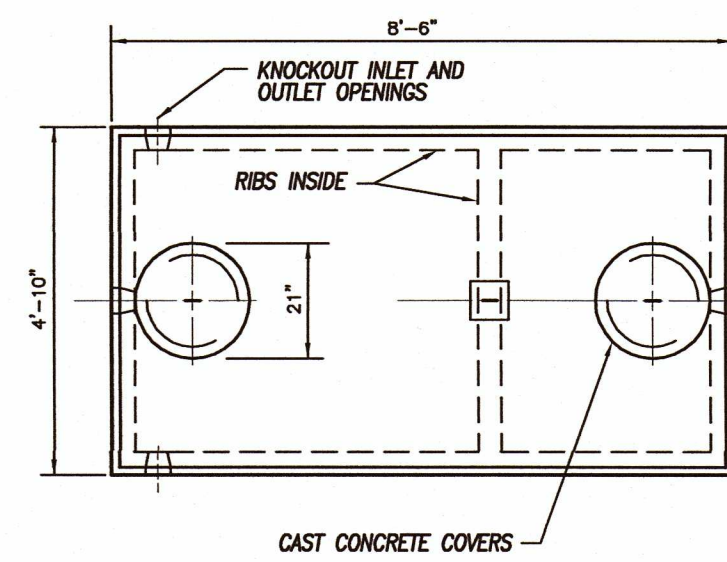

**PLAN**

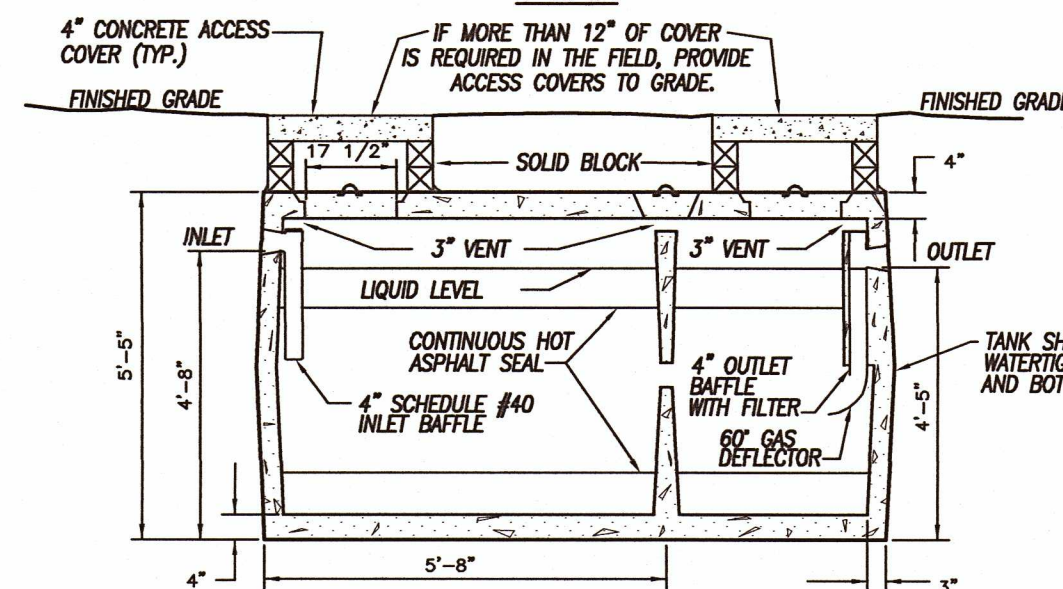

**CROSS SECTION**

**1000 GALLON 2 COMPARTMENT SEPTIC TANK**

NOT TO SCALE

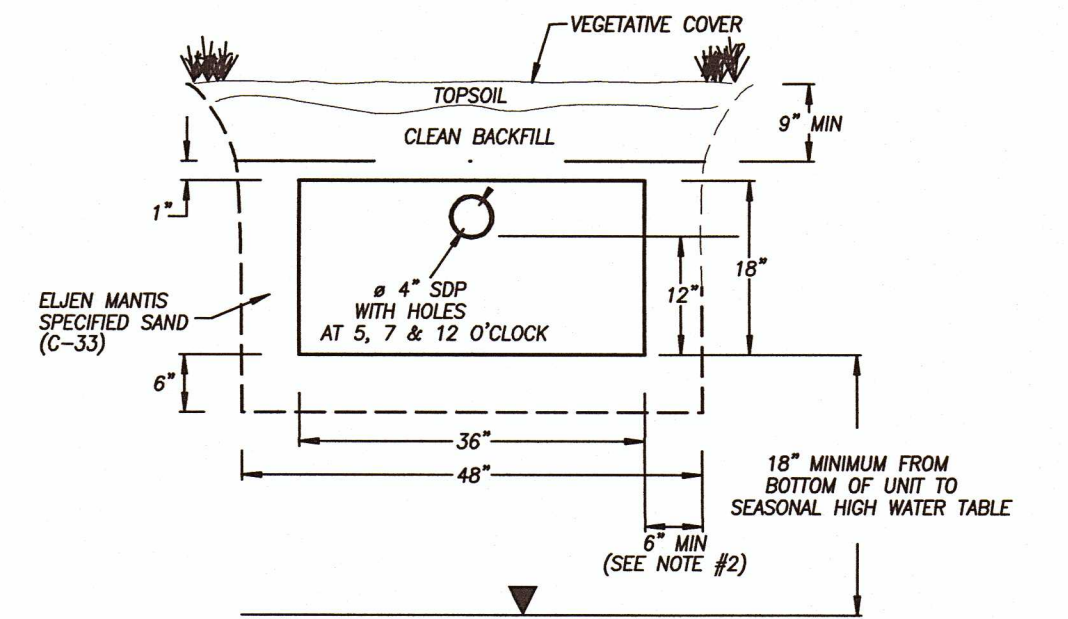
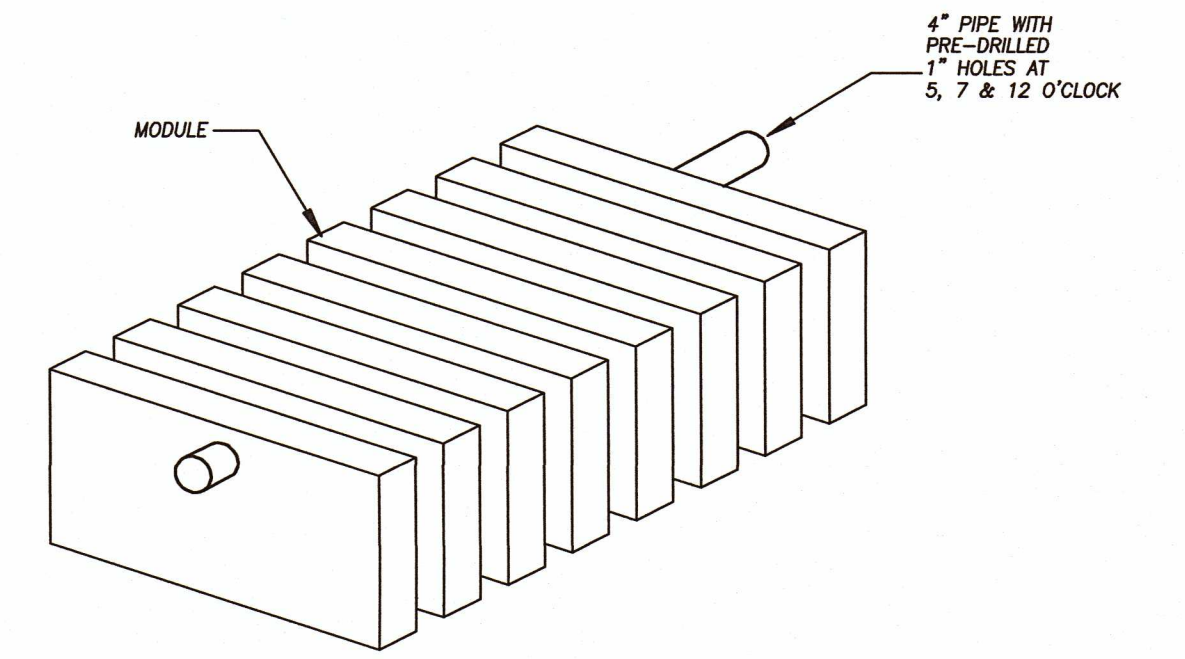

- NOTES:
1. VENTING REQUIRED WHEN MORE THAN 18" OF COVER AS MEASURED FROM THE TOP OF THE UNIT TO FINISHED GRADE.
  2. FOR SYSTEMS INSTALLED IN FILL, CONTRACTOR SHALL PROVIDE 5" OF SELECT FILL OR ASTM C-33 SAND 5' AROUND PERIMETER OF SYSTEM.

**ELJEN 536-8 WASTEWATER LEACHING SYSTEM**

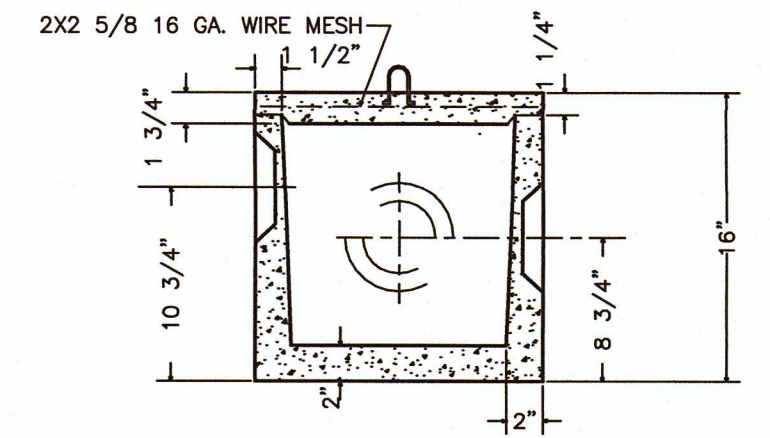

**STANDARD D-BOX**

NOT TO SCALE

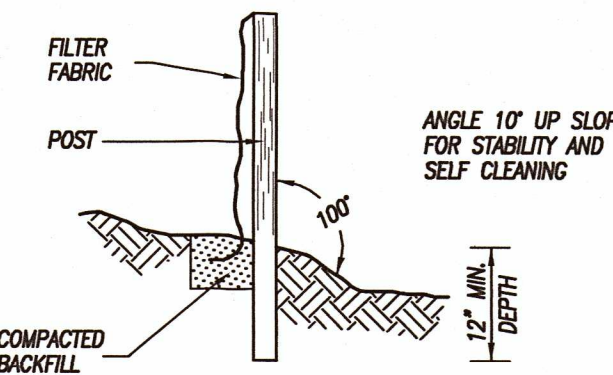

**SILT FENCE**

NOT TO SCALE

DATE	DESCRIPTION
1/19/2021	SIGHTLINE DEMONSTRATION & PROPOSED DRIVE PROFILE ADDED
	REVISIONS

**DETAIL SHEET**

PREPARED FOR

**SEAN O'KEEFE**

341 BREAKNECK HILL ROAD  
KILLINGLY, CONNECTICUT

**Killingly Engineering Associates**  
Civil Engineering & Surveying

114 Westcott Road  
P.O. Box 421  
Killingly, Connecticut 06241  
(860) 779-7299  
www.killinglyengineering.com

DATE: 10/22/2019	DRAWN: AMR
SCALE: NOT TO SCALE	DESIGN: NET
SHEET: 4 OF 4	CHK BY: GG
DWG. No: CLIENT FILE	JOB No: 19114



Norman Thibault, Jr. 10/21/2021  
DATE