

CROSS SECTION "A-A"
SCALE: 1" = 5'

PERCOLATION TEST RESULT - May 30, 2007
NORTHEAST DISTRICT DEPARTMENT OF HEALTH

HOLE A
Depth = 28"

Time	Reading
10:45	6"
10:50	21"
10:55	23"
11:10	25"
11:20	26.75"

Rate = 5.7 min./in.

TEST HOLE DATA - May 30, 2007
NORTHEAST DISTRICT DEPARTMENT OF HEALTH

TEST PIT	DEPTH	PROFILE
1	0" - 8"	Topsoil
	8" - 28"	Brown Silty Fine Sandy Loam
	28" - 84"	Mottled Gray Compact Sandy Loam
	Ledge	N/A
	GWT	58"
2	0" - 8"	Topsoil
	8" - 28"	Brown Silty Fine Sandy Loam
	28" - 72"	Mottled Gray Compact Sandy Pan
	Ledge	N/A
	GWT	24"

SEPTIC SYSTEM DESIGN DATA

Percolation Rate = 10 min. / in.
 3 bedroom house requires = 495 s.f. effective leaching area
 Effective Leaching area = 11 s.f. / l.f. of Eljen Mantis 536-8
 Length Required = 495/11 = 45 l.f.
 Length Provided = 45 l.f.
 Min. Leaching System Spread (MLSS) = 26 x 1.5 x 1.0 = 39'
 MLSS Provided = 45'
LEACHING FIELD
 one 45' row (9 Sections) of Eljen Mantis 536-8 Septic Leaching Units
 Maximum depth into existing grade = 5'

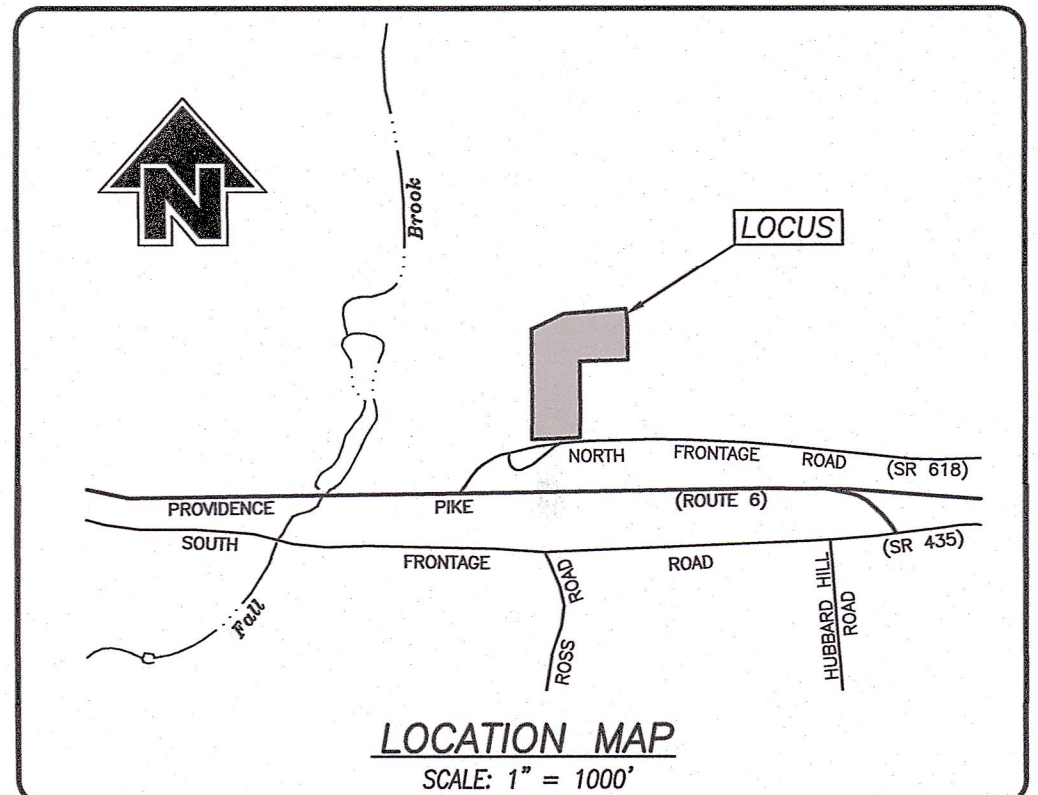

TEST HOLE DATA - August 29, 2023
Killingly Engineering & NDDH

TEST PIT	DEPTH	PROFILE
101	0" - 4"	Topsoil/Organics
	4" - 23"	Brown Sandy Loam, Fines
	23" - 82"	Mottled Gray Very Fine Sandy Loam, Moist
	82" - 84"	Groundwater
	Ledge	N/A
	GWT	82" Seeps @ 56"
	Mottling	23"
102	0" - 8"	Topsoil/Organics
	8" - 26"	Brown Sandy Loam
	26" - 84"	Mottled Gray Very Fine Sandy Loam, Moist
	84" - 86"	Groundwater
	Ledge	N/A
	GWT	56"
	Mottling	26" Heavy @ 35"

PERCOLATION TEST RESULT - August 29, 2023
Killingly Engineering & NDDH

HOLE A1
Depth = 22"

Time	Reading
2:10	3.5"
2:15	5"
2:20	6.5"
2:25	8"
2:32	10"
2:35	11"
2:40	12"
2:45	12.5"
2:50	13"

Rate = 10 min./in.

NOTES:

- This survey has been prepared pursuant to the Regulations of Connecticut State Agencies Sections 20-300b-1 through 1. 20-300b-20 and the "Standards for Surveys and Maps in the State of Connecticut" as adopted by the Connecticut Association of Land Surveyors, Inc. on September 26, 1996;
 - This survey conforms to a Class "A-2" horizontal accuracy.
 - Topographic features conform to a Class "T-2", "V-2" vertical accuracy.
 - Survey Type: Improvement Location Survey.
 - Boundary Determination Category: Resurvey
2. Zone = RD.
 3. Owner of record: Edward & Lynn Martins
 620 Steere Farm Road
 Harrisville, RI 02830
 4. Parcel is shown as Lot #5.1 on Assessors Map #222.
 5. Elevations shown are based on North American Vertical Datum of 1988 (NAVD 88). Contours taken from the Town of Killingly's GIS data and supplemented with actual field survey. Contour interval = 2'.
 6. North orientation, bearings and coordinate values shown are based on North American Datum of 1983 (NAD 83) and are taken from GPS readings.
 7. Test Pit data taken from map reference and from NDDH File #24000025.
 8. Wetlands shown were delineated in the field by Michael Schaefer, Certified Soil Scientist, and were taken from map reference.
 9. Before any construction is to commence contact "CALL BEFORE YOU DIG" at 1-800-922-4455 or 811.

MAP REFERENCE:

- "Subdivision Plan - Prepared for - Estate of John N. Kogut, Jr. - North Frontage Road - Killingly, Connecticut - Scale: 1" = 100' - Date: 7/15/2007 - Sheet 1 of 3 - Prepared by: KWP Associates."
- "Compilation Plan - Map Showing Easement Area to be Granted to The Connecticut Light & Power Company d.b.a Eversource Energy Across the Property of - Lynn V. Martins & Edward S. Martins 28 North Frontage Road - Killingly, Connecticut - Scale: 1" = 40' - Date: 05/04/2022 - Revised to: 07/26/2022 - Prepared by: Killingly Engineering Associates". On file in the Killingly Land Records as Map #7399.

SEPTIC TANK
 1000 GALLON
 TWO COMPARTMENT
 F/L IN = 427.90
 F/L OUT = 427.65
 DISTRIBUTION BOXES
 D-1 (STANDARD)
 F/L IN = 427.05
 F/L OUT = 426.90

SURVEYOR SHALL SET A BENCH MARK IN THE AREA OF THE SEPTIC SYSTEM AT THE TIME OF CONSTRUCTION STAKE-OUT.

RECEIVED
 SEP 06 2023
 PLANNING & ZONING DEPT.
 TOWN OF KILLINGLY

TO MY KNOWLEDGE AND BELIEF, THIS MAP IS SUBSTANTIALLY CORRECT AS NOTED HEREON.

GREG A. GLAUDE, L.S. LIC. NO. 70191 DATE 9-06-2023

NO CERTIFICATION IS EXPRESSED OR IMPLIED UNLESS THIS MAP BEARS THE ORIGINAL SEAL AND SIGNATURE OF THE LAND SURVEYOR.

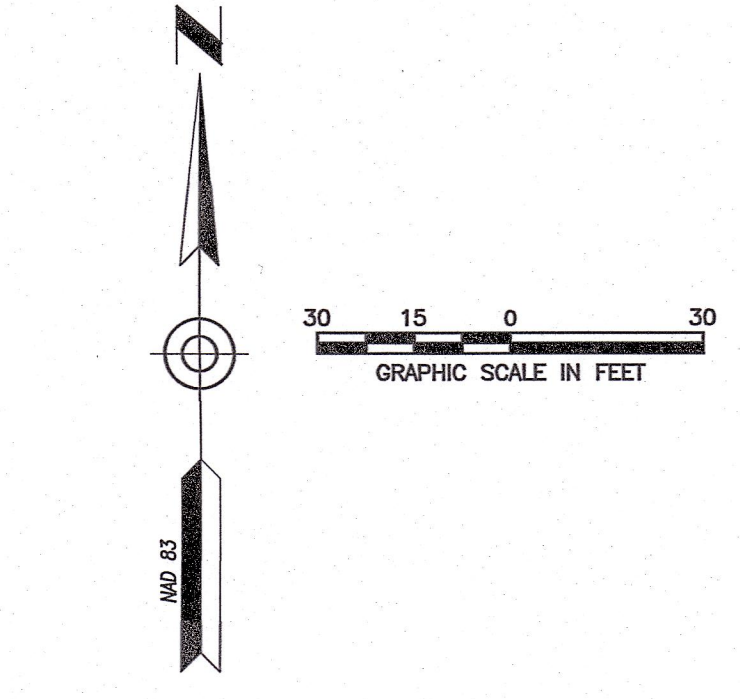

5-2
n/f

Neil Barnett & Kristie Barnett
Map 222, Lot 5.2

5-2
n/f

Neil Barnett & Kristie Barnett
Map 222, Lot 5.2

5-1
AREA = 5.21 ACRES

5
n/f

Joseph R. Balcher, III & Heather G. Balcher
Map 222, Lot 5

There is no apparent well or septic system within 75' of proposed development.

- LEGEND
- F.F. FINISHED FLOOR
 - IRON PIN FOUND
 - EXISTING CONTOURS
 - PROPOSED CONTOURS
 - INLAND WETLANDS FLAG
 - BUILDING SETBACK LINE
 - PERCOLATION TEST HOLE
 - TEST HOLE
 - STONE WALL
 - SILT FENCE

ANY CHANGES TO THESE PLANS WITHIN 200' OF WETLANDS OR WATERCOURSES MUST BE RESUBMITTED TO THE KILLINGLY INLAND WETLANDS AND WATERCOURSES COMMISSION FOR ITS APPROVAL.

THE APPLICANT WILL CONTACT THE KILLINGLY INLAND WETLANDS AND WATERCOURSES COMMISSION'S AGENT AFTER ALL EROSION AND SEDIMENT CONTROL MEASURES ARE INSTALLED, PRIOR TO ANY CONSTRUCTION OR EXCAVATION ON THE PROPERTY.

APPROVED BY THE TOWN OF KILLINGLY INLAND WETLANDS COMMISSION

CHAIRMAN DATE

FORWARD THIBEAULT, JR., P.E. No. 22834 DATE 9/6/2023

EROSION AND SEDIMENT CONTROL NARRATIVE:

PRINCIPLES OF EROSION AND SEDIMENT CONTROL

The primary function of erosion and sediment controls is to absorb erosional energies and reduce runoff velocities that force the detachment and transport of soil and/or encourage the deposition of eroded soil particles before they reach any sensitive area.

KEEP LAND DISTURBANCE TO A MINIMUM

The more land that is in vegetative cover, the more surface water will infiltrate into the soil, thus minimizing stormwater runoff and potential erosion. Keeping land disturbance to a minimum not only involves minimizing the extent of exposure at any one time, but also the duration of exposure. Phasing, sequencing and construction scheduling are interrelated. Phasing divides a large project into distinct sections where construction work over a specific area occurs over distinct periods of time and each phase is not dependent upon a subsequent phase in order to be functional. A sequence is the order in which construction activities are to occur during any particular phase. A sequence should be developed on the premise of "first things first" and "last things last" with proper attention given to the inclusion of adequate erosion and sediment control measures. A construction schedule is a sequence with time lines applied to it and should address the potential overlap of actions in a sequence which may be in conflict with each other.

- Limit areas of clearing and grading. Protect natural vegetation from construction equipment with fencing, tree armoring, and retaining walls or tree wells.
- Route traffic patterns within the site to avoid existing or newly planted vegetation.
- Phase construction so that areas which are actively being developed at any one time are minimized and only that area under construction is exposed. Clear only those areas essential for construction.
- Sequence the construction of storm drainage systems so that they are operational as soon as possible during construction. Ensure all outlets are stable before outletting storm drainage flow into them.
- Schedule construction so that final grading and stabilization is completed as soon as possible.

SLOW THE FLOW

Detachment and transport of eroded soil must be kept to a minimum by absorbing and reducing the erosive energy of water. The erosive energy of water increases as the volume and velocity of runoff increases. The volume and velocity of runoff increases during development as a result of reduced infiltration rates caused by the removal of existing vegetation, removal of topsoil, compaction of soil and the construction of impervious surfaces.

- Use diversions, stone dikes, silt fences and similar measures to break flow lines and dissipate storm water energy.
- Avoid diverting one drainage system into another without calculating the potential for downstream flooding or erosion.

KEEP CLEAN RUNOFF SEPARATED

Clean runoff should be kept separated from sediment laden water and should not be directed over disturbed areas without additional controls. Additionally, prevent the mixing of clean off-site generated runoff with sediment laden runoff generated on-site until after adequate filtration of on-site waters has occurred.

- Segregate construction waters from clean water.
- Divert site runoff to keep it isolated from wetlands, watercourses and drainage ways that flow through or near the development until the sediment in that runoff is trapped or detained.

REDUCE ON SITE POTENTIAL INTERNALLY AND INSTALL PERIMETER CONTROLS

While it may seem less complicated to collect all waters to one point of discharge for treatment and just install a perimeter control, it can be more effective to apply internal controls to many small sub-drainage basins within the site. By reducing sediment loading from within the site, the chance of perimeter control failure and the potential off-site damage that it can cause is reduced. It is generally more expensive to correct off-site damage than it is to install proper internal controls.

- Control erosion and sedimentation in the smallest drainage area possible. It is easier to control erosion than to contend with sediment after it has been carried downstream and deposited in unwanted areas.
- Direct runoff from small disturbed areas to adjoining undisturbed vegetated areas to reduce the potential for concentrated flows and increase settlement and filtering of sediments.
- Concentrated runoff from development should be safely conveyed to stable outlets using rip rapped channels, waterways, diversions, storm drains or similar measures.
- Determine the need for sediment basins. Sediment basins are required on larger developments where major grading is planned and where it is impossible or impractical to control erosion at the source. Sediment basins are needed on large and small sites when sensitive areas such as wetlands, watercourses, and streets would be impacted by off-site sediment deposition. Do not locate sediment basins in wetlands or permanent or intermittent watercourses. Sediment basins should be located to intercept runoff prior to its entry into the wetland or watercourse.

SEPTIC SYSTEM CONSTRUCTION NOTES

- The building, septic system and well shall be accurately staked in the field by a licensed Land Surveyor in the State of Connecticut, prior to construction.
- Topsoil shall be removed and in the area of the primary leaching field scarified, prior to placement of septic fill. Septic fill specifications are as follows:
 - Max. percent of gravel (material between No. 4 & 3 inch sieves) = 45%

GRADATION OF FILL (MINUS GRAVEL)

SIEVE SIZE	PERCENT PASSING (WET SIEVE)	PERCENT PASSING (DRY SIEVE)
No. 4	100%	100%
No. 10	70% - 100%	70% - 100%
No. 40	10% - 50%	10% - 75%
No. 100	0% - 20%	0% - 5%
No. 200	0% - 5%	0% - 2.5%

Fill material shall be approved by the sanitarian prior to placement. It shall be compacted in 6" lifts and shall extend a minimum of five feet (5') around the perimeter of the system. Common fill shall extend an additional five feet (5') down gradient of the system (10' total) before tapering off at a maximum slope of 2H:1V.

- Septic tank shall be two compartment precast 1000 gallon tank with gas deflector and outlet filter as manufactured by Jolley Precast, Inc. or equal.
- Distribution boxes shall be 4 hole precast concrete as manufactured by Jolley Precast, Inc. or equal.
- All precast structures such as septic tanks, distribution boxes, etc. shall be set level on six inches (6") of compacted gravel base at the elevations specified on the plans.
- Solid distribution pipe shall be 4" diameter PVC meeting ASTM D-3034 SDR 35 with compression gasketed joints. It shall be laid true to the lines and grades shown on the plans and in no case have a slope less than 0.125 inches per foot.
- Perforated distribution pipe shall be 4" diameter PVC meeting ASTM D-3034 or ASTM F1760 for SDR 35, or ASTM F810 for SDR 38.
- Sewer pipe from the foundation wall to the septic tank shall be schedule 40 PVC meeting ASTM D 1785. It shall be laid true to the grades shown on the plans and in no case shall have a slope less than 0.25 inches per foot.
- Solid footing drain outlet pipe shall be 4" Diameter PVC meeting ASTM D 3034, SDR 35 with compression gasketed joints. Footing drain outlet pipe shall not be backfilled with free draining material, such as gravel, broken stone, rock fragments, etc.
- Septic sand shall meet the requirements of ASTM C-33 with less than 10% passing a 100 sieve and less than 5% passing a 200 sieve

SIEVE SIZE	% PASSING
0.375	100
#4	95-100
#8	80-100
#16	60-85
#30	25-60
#50	10-30
#100	<10
#200	<5

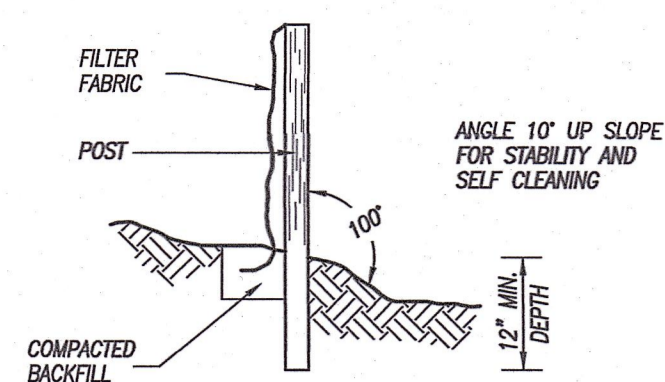

SILT FENCE

NOT TO SCALE

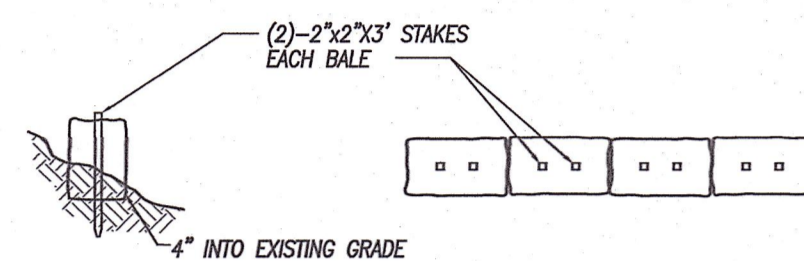

HAYBALE BARRIER

NOT TO SCALE

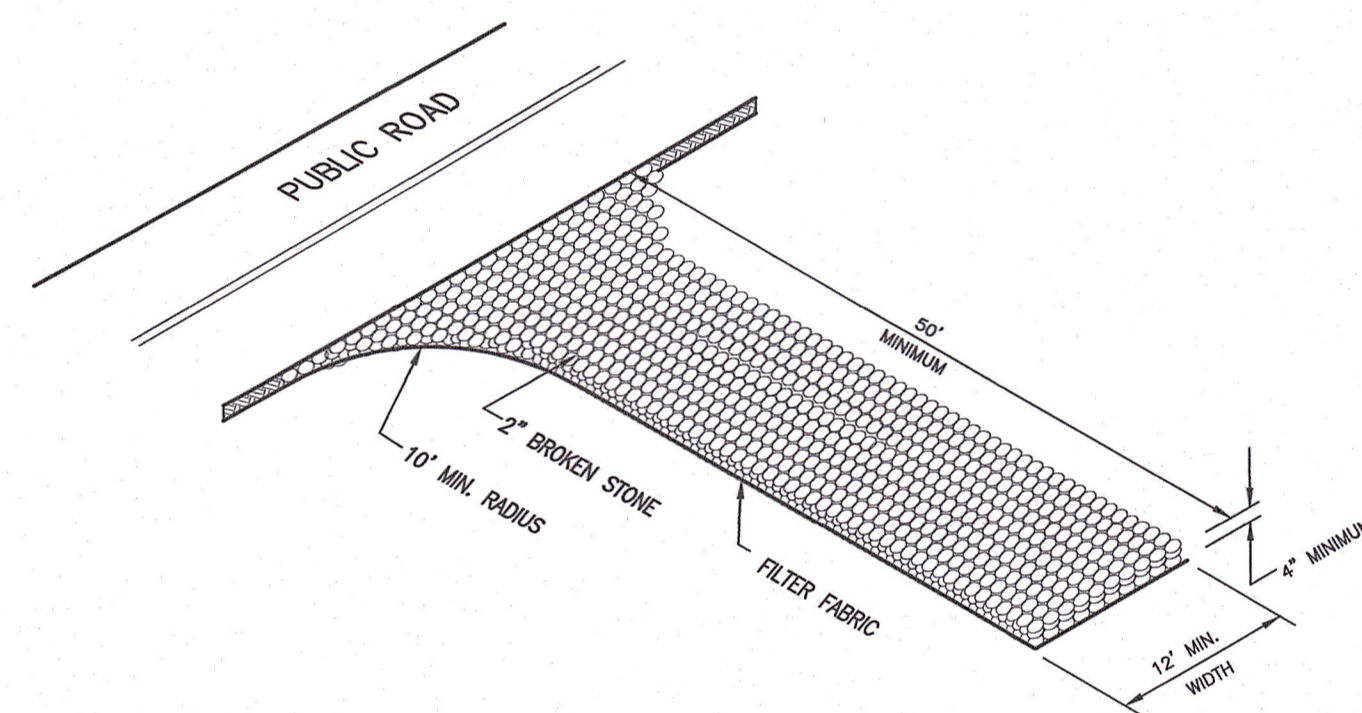

ANTI-TRACKING PAD

NOT TO SCALE

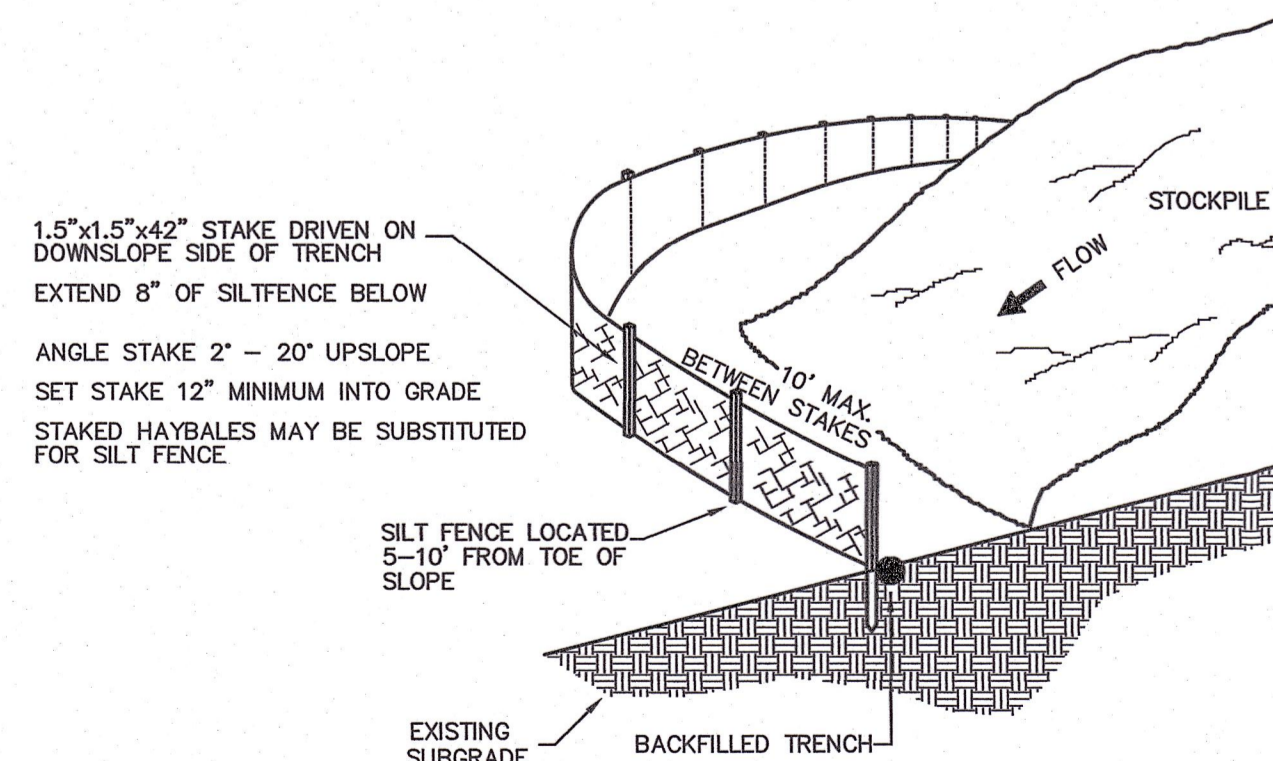

SILT FENCE @ TOE OF SLOPE APPLICATION

NOT TO SCALE

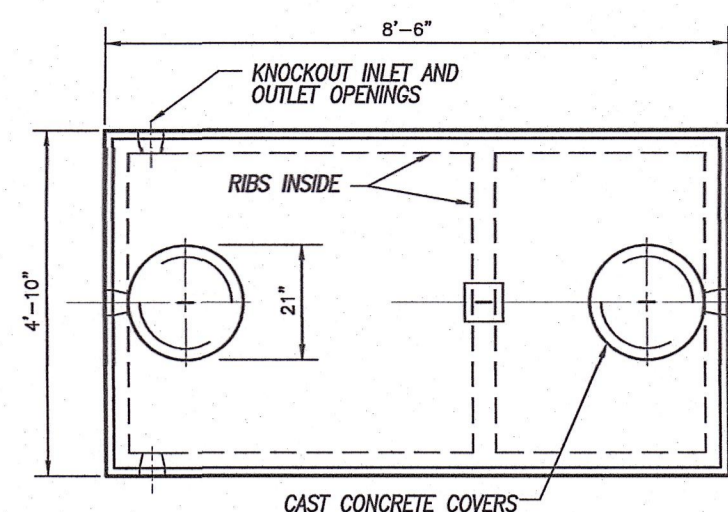

PLAN

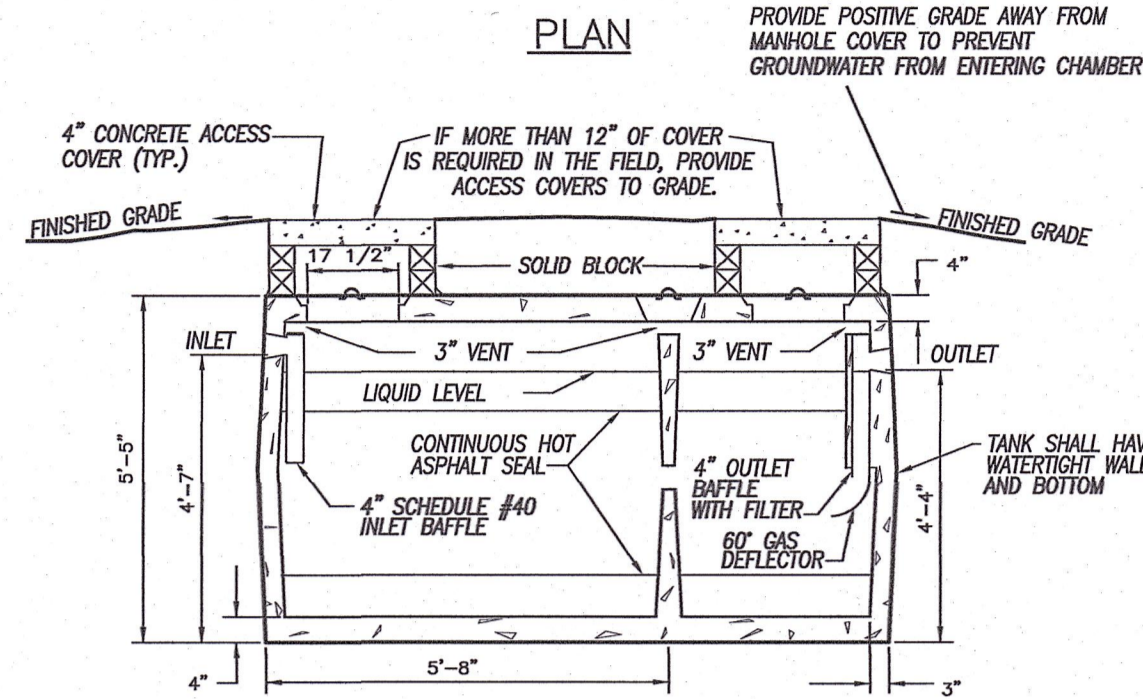

CROSS SECTION

**1000 GALLON
2 COMPARTMENT
SEPTIC TANK**

NOT TO SCALE

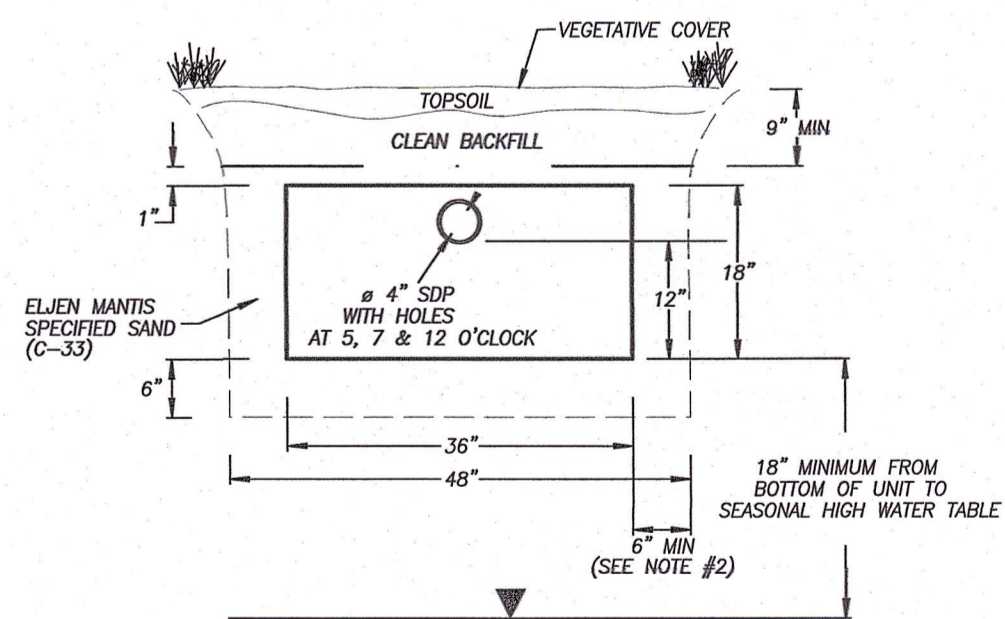
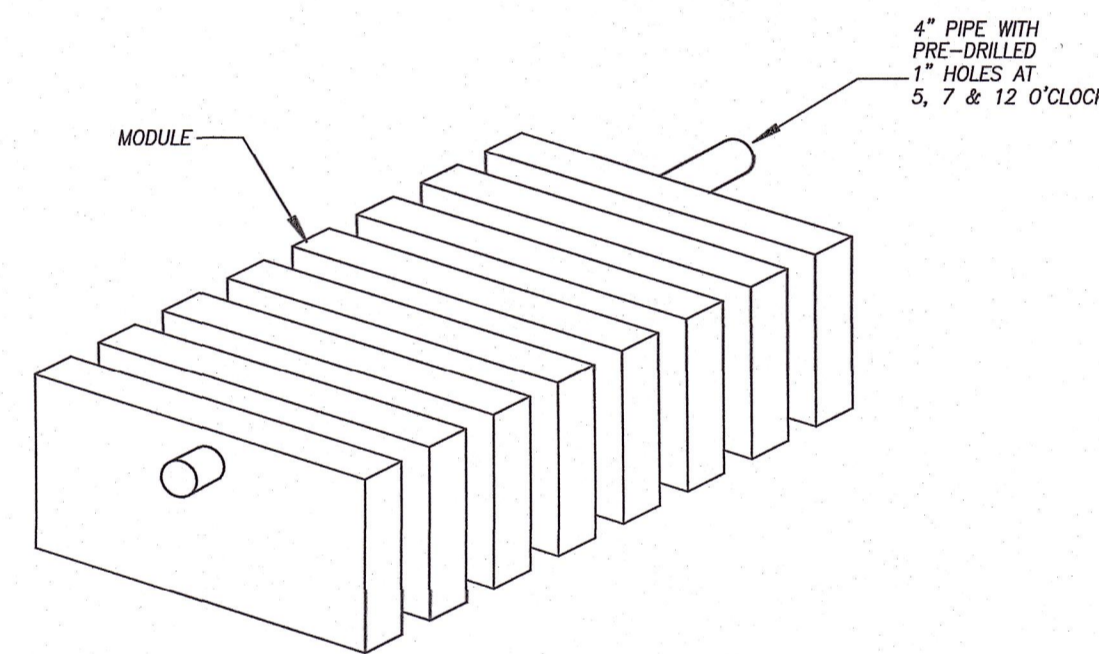

NOTES:

- VENTING REQUIRED WHEN MORE THAN 18" OF COVER AS MEASURED FROM THE TOP OF THE UNIT TO FINISHED GRADE.
- FOR SYSTEMS INSTALLED IN FILL, CONTRACTOR SHALL PROVIDE 5' OF SELECT FILL OR ASTM C-33 SAND 5' AROUND PERIMETER OF SYSTEM.

**ELJEN 536-8 WASTEWATER
LEACHING SYSTEM**

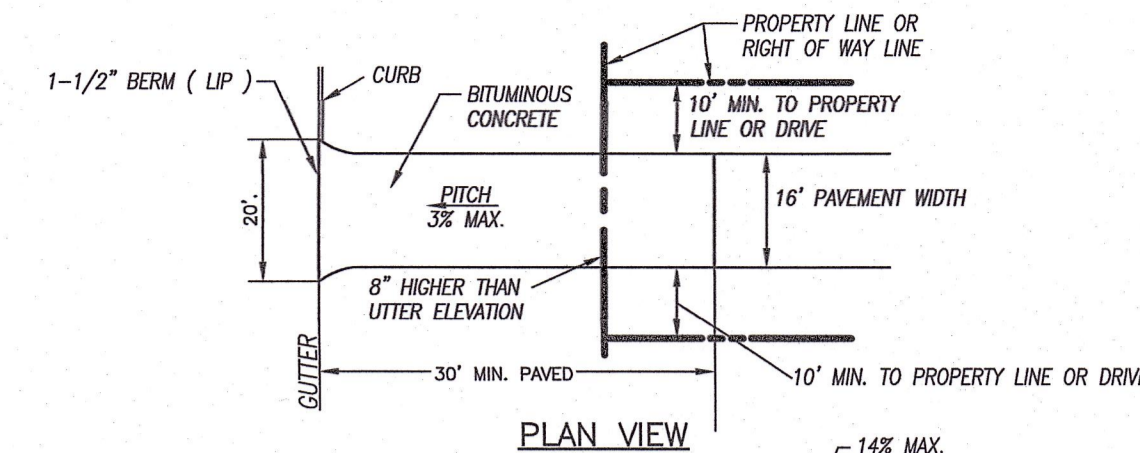

PLAN VIEW

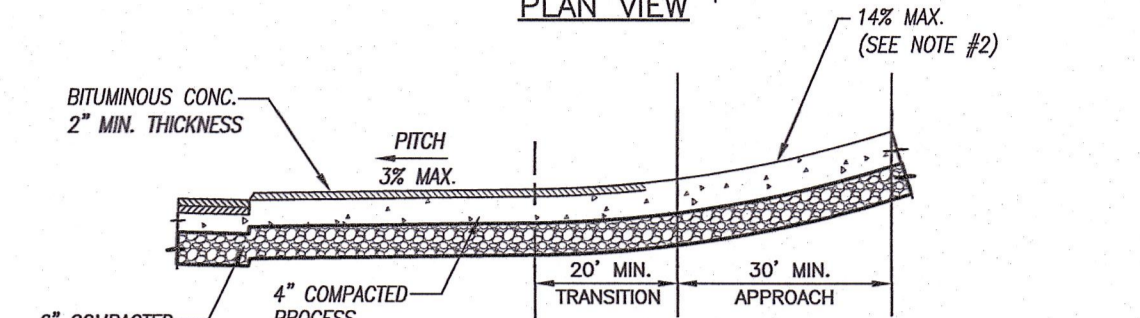

**LAND ABOVE ROAD
(SECTION)**

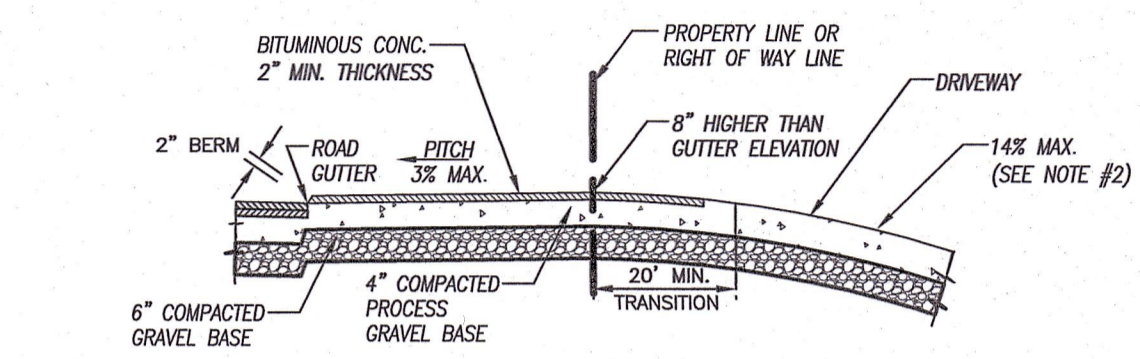

**LAND BELOW ROAD
(SECTION)**

- THE ABOVE DETAIL IS ILLUSTRATIVE ONLY AND DOES NOT APPLY TO EVERY SITUATION. REVIEW YOUR DRIVEWAY PERMIT FOR YOUR SPECIFIC REQUIREMENTS.
- DRIVEWAYS IN EXCESS OF 106 GRADE, AND ALL COMMON (SHARED) DRIVEWAYS SHALL BE PAVED WITH BITUMINOUS CONCRETE.

STANDARD COMMON DRIVE DETAIL

NOT TO SCALE

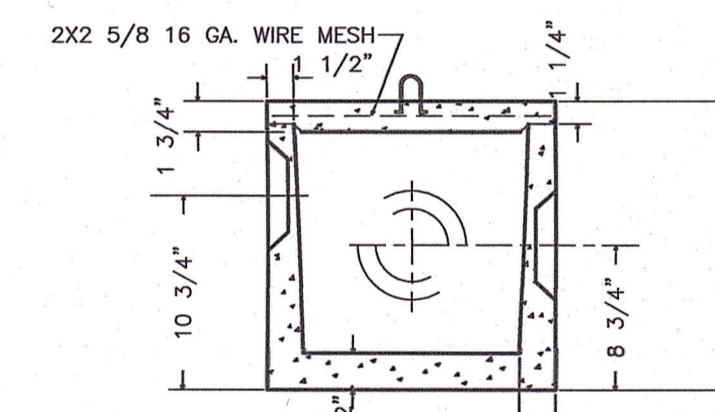

STANDARD D-BOX

NOT TO SCALE

DATE	DESCRIPTION

DETAIL SHEET - LOT 5-1

PREPARED FOR

**EDWARD S. MARTINS &
LYNN V. MARTINS**

34 NORTH FRONTAGE ROAD
KILLINGLY, CONNECTICUT

Killingly Engineering Associates
Civil Engineering & Surveying



114 Westcott Road
P.O. Box 421
Killingly, Connecticut 06241
(860) 779-7299
www.killinglyengineering.com

DATE: 7/28/2023	DRAWN: AMR
SCALE: NOT TO SCALE	DESIGN: NET
SHEET: 2 OF 2	CHK BY: GG
DWG. No: CLIENT FILE	JOB No: 21022

RECEIVED

SEP 06 2023

PLANNING & ZONING DEPT.
TOWN OF KILLINGLY

Normand Thibault 9/6/2023
NORMAND THIBAUT, J.R., P.E. No. 22834 DATE